









SI-MAG Series Magnetic Style Switch Features

- Non-contact safety switches are the best choice for washdown applications; the switch components are sealed and rated NEMA 4X, IEC IP67
- Tolerant of dirt buildup, sensing distance, and alignment
- System consists of three components:
 - Coded magnet
 - Reed switch sensor
 - Controller module
- Magnet contains several differently-polarized magnets, and sensor contains pole-stable reed contacts to minimize any possibility of defeat
- Easy installation; can be concealed for added defeat resistance
- Sensor reed switches provide diverse input to the controller module

Magnetic Style Safety Switch Models

	Magnet Sensor*	Coded Magnet		Controller	Sensor Cable	Switching Distance	
						Min. ON	Max OFF
SI-MAG1SM SI-MAG1SMCO†		SI-MAG1MM		SI-MAG1C	3 m (10 ft)	3 mm (0.12")	14 mm (0.55")
		SI-MAG1MMHF				8 mm (0.31")	16 mm (0.63")
SI-MAG2SM		SI-MAG2MM				4 mm (0.16")	8 mm (0.32")
SI-MAG3SM		SI-MAG3MM				3 mm (0.12")	7 mm (0.28")

*NOTES: • 9 m (30') cables are available for magnet sensors by adding suffix "W/30" to the model number of the cabled version (e.g., SI-MAG1SM w/30).

† Cable Opposite



Machine Safety Switches – Magnet Style



Important Information Regarding the Use of Safety Switches

In the United States, the functions that Banner safety switches are intended to perform are regulated by the Occupational Safety and Health Administration (OSHA). Whether or not any particular safety switch installation meets all applicable OSHA requirements depends upon factors that are beyond the control of Banner Engineering Corp. These factors include the details of how the safety switches are applied, installed, wired, operated, and maintained.

Banner Engineering Corp. has attempted to provide complete application, installation, operation, and maintenance instructions. This information is found in the instruction manual packaged with each safety switch. In addition, we suggest that any questions regarding the use or installation of safety switches be directed to the factory applications department at the telephone numbers or address shown, below.

Banner Engineering Corp. recommends that safety switches be applied according to the guidelines set forth in international (ISO/IEC) standards listed, below. Specifically, Banner Engineering Corp. recommends application of safety switches in a configuration which meets safety category 4, per ISO 13849 (EN954-1).

In addition, the user of Banner safety switches has the responsibility to ensure that all local, state, and national laws, rules, codes, and regulations relating to the use of Banner safety switches in any particular application are satisfied. Extreme care is urged that all legal requirements have been met and that all installations and maintenance instructions are followed.

Application Assistance

Toll Free: 1-888-3-SENSOR (1-888-373-6767)
Email: sensors@bannerengineering.com
Address: 9714 Tenth Avenue North
Minneapolis, MN 55441

U.S. Regulations Applicable to Use of Banner Safety Switches

OSHA Code of Federal Regulations: Title 29, Parts 1900 to 1910

Available from: Superintendent of Documents
Government Printing Office
P.O. Box 371954
Pittsburgh, PA 15250-7954
Tel: 202-512-1800

U.S. Standards Applicable to Use of Banner Safety Switches

ANSI B11 "Standards for Construction, Care, and Use of Machine Tools"
Available from: Safety Director
AMT - The Association for Manufacturing Technology
7901 Westpark Drive
McLean, VA 22102
Tel: 703-893-2900

Applicable European and International Standards

ISO/TR 12100-1 "Safety of Machinery - Basic Concepts, General Principles for Design"
(EN292-18-2)
ISO 13852 (EN 294) "Safety of Machinery - Safety Distances to Prevent Danger Zones Being Reached by the Upper Limbs"
ISO 13853 (EN 811) "Safety of Machinery - Safety Distances to Prevent Danger Zones Being Reached by the Lower Limbs"
ISO 13849 (EN 954-1) "Safety of Machinery - Safety Related Parts of Control Systems"
ISO 13855 (EN 999) "Safety of Machinery - The Positioning of Protective Equipment in Respect to Approach Speeds of Parts of the Human Body"
ISO 14119 (EN 1088) "Safety of Machinery - Interlocking Devices Associated with Guards - Principles for Design and Selection"
IEC/EN 60204-1 "Safety of Machinery - Electrical Equipment of Machines"
IEC/EN 60947-5-1 "Low Voltage Switchgear -Electromechanical Control Circuit Devices"

Available from: Global Engineering Documents
15 Inverness Way East
Englewood, CO 80112-5704
Phone: 1-800-854-7179
Fax: 303-397-2740

Machine Safety Switches – Magnet Style

Sensor and Magnet Installation

Magnetic style safety switches are easily mounted on the inside edge of most guards. Inside mounting can often hide them from view and discourage tampering.

All mounting hardware is supplied by the user. Use of permanent fasteners or locking hardware is recommended to prevent loosening or displacement of the actuator and switch body. Mounting holes in the magnet and sensor accept M4 (#6) hardware (see drawings, on page 8).

Position the magnet and sensor in the mounting location with the magnet surface directly opposite the sensing surface (see dimension drawings). Leave a slight gap (up to 3 mm or 0.12") between the magnet and sensor surfaces, so that the magnet and sensor do not act as an end stop when the guard is closed. Mark the mounting holes. Fasten the magnet and sensor in place. After the mounting hardware is secure, check the magnet and sensor alignment and sensing gap. Neither is critical, but the gap should be less than 3 mm (0.12") for reliable sensor actuation.

Route the sensor cable to the controller location. The controller must be installed inside an enclosure. It is not designed for exposed wiring. It is the user's responsibility to house the controller in an enclosure with NEMA (or IEC) rating which is suitable for the operating environment. The controller mounts onto standard 35 mm DIN rail.

Note: The typical direction of approach of a magnet to its corresponding sensor is normally perpendicular to the sensing face and the magnet surface (see dimensional drawings on page 8 and Figures 2a, 2b and 2c, "Direction of Approach on page 6). Alternate directions are possible (e.g., sideways or parallel), though the speed of approach must be fast enough to meet the simultaneity-monitoring period of 0.5 seconds. This speed is approximately equal to or greater than 0.2 m (8"/s). If the simultaneity is not met, the MAG1C controller will not close its safety output contacts, even if the "sensor" indicator is OFF.

IMPORTANT NOTE: If the sensor or magnet is mounted on a material that can be magnetized (e.g., ferrous metal, such as iron), the switching distance will be affected. The sensor and magnet must be mounted a minimum distance of 15 mm (0.6") from magnetized or ferrous materials for proper operation.

IMPORTANT NOTE: The magnet and sensor are coded to minimize the possibility of false actuation. Nevertheless, they should not be used within known fields of high-level electromagnetic radiation. The magnet and sensor must never be used as a mechanical stop.

Electrical Installation

Each controller is powered by 24V dc (at less than 100 mA). The controller, in turn, supplies power to the sensor.

As illustrated in Figure 1, the safety output (terminals 71 and 76) from each of **two safety switches per interlock guard** must connect to a 2-channel safety module or safety interface in order to achieve a control reliable interface to the master stop control elements of a machine. Examples of appropriate safety modules include 2-channel emergency stop (E-stop) safety modules and gate monitor safety modules.

Two functions of the safety module or safety interface are:

- 1) to provide a means of monitoring the contacts of both safety switches for contact failure, and to prevent the machine from restarting if either switch fails;



WARNING!

It must not be possible for personnel to reach any hazard point through an opened guard (or any opening) before hazardous machine motion has completely stopped. Please reference OSHA CFR 1910.217 and ANSI B11 standards (see page 2) for information on determining safety distances and safe opening sizes for your guarding devices.

Machine Safety Switches – Magnet Style

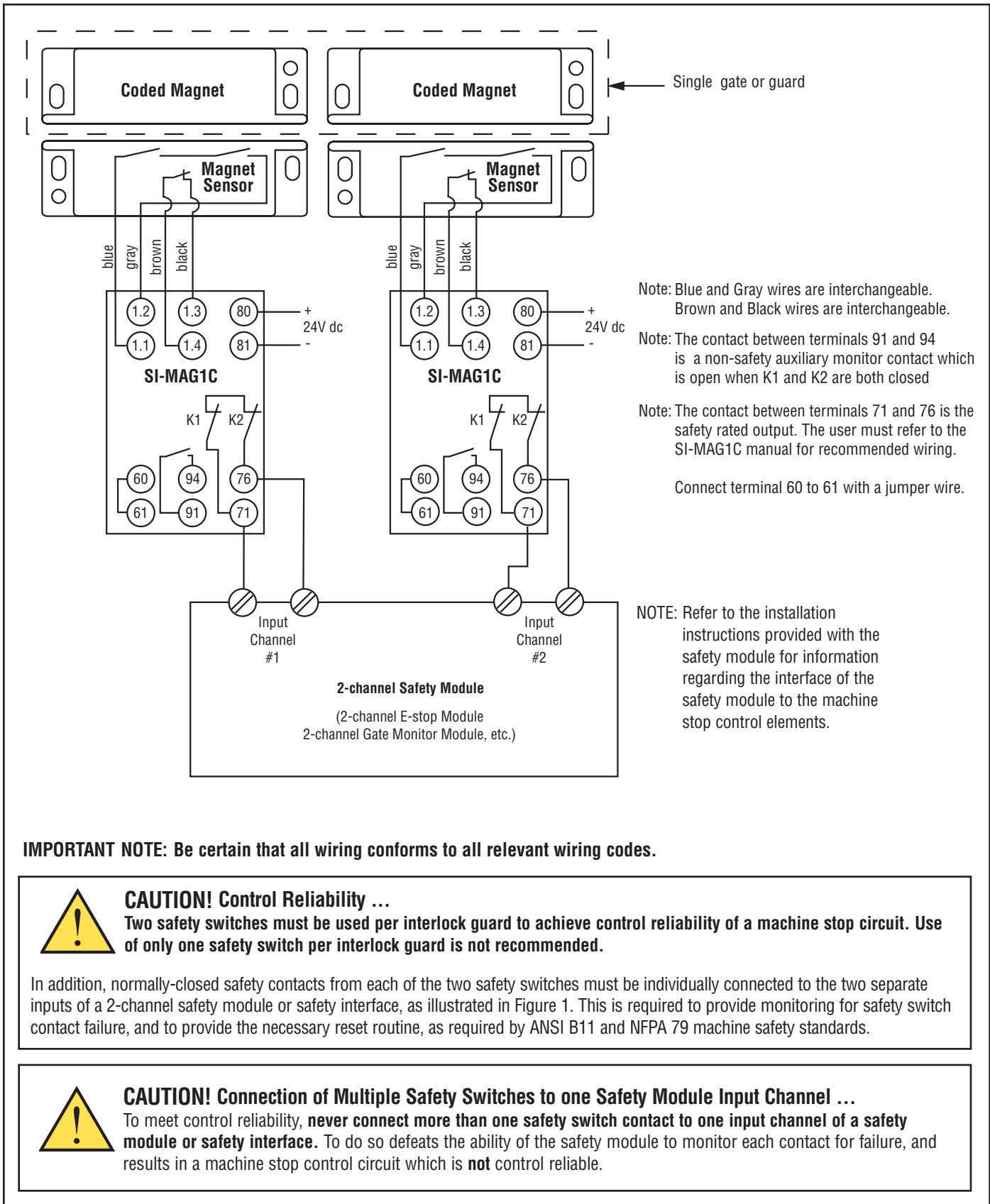

Figure 1. Connect two redundant safety switches per interlock guard to an appropriate 2-channel input safety module.

Machine Safety Switches – Magnet Style

- 2) to provide a reset routine after closing the guard and returning the safety contacts to their closed position - this prevents the controlled machinery from restarting by simply reinserting the safety switch actuators. This necessary reset function is required by ANSI B11 and NFPA 79 machine safety standards.

Use only the safety output between terminals 71 and 76 of the MAG1C controllers for inputs to the safety module or safety interface (see Figure 1). The auxiliary contact between terminals 91 and 94 is not safety-rated and should only be used for monitoring functions, such as to communicate with a process controller or PLC. In normal operation, the output of the auxiliary contact is opposite of the safety output.

Terminals 60 and 61 are External Device Monitoring (EDM) inputs and must be connected to normally-closed forced-guided monitor contacts of the machine stop control elements or jumpered if the monitoring of these elements is accomplished by other means, such as by the safety module or safety interface.

Refer to the installation instructions provided with the safety module for more information regarding the interfacing of the safety module to the machine stop control elements.

Periodic Checks

We recommend that safety switches be checked at each shift change or machine setup by a *designated* person for:

- 1) Breakage of the sensor or magnet,
- 2) Good alignment of the magnet with the sensor,
- 3) Confirmation that the sensor and magnet are not being used as an end stop,
- 4) Loosening of the sensor or magnet mounting hardware.
- 5) Verify that it is not possible to reach any hazard point through an opened guard (or any opening) before hazardous machine motion has completely stopped.

In addition, we recommend that a qualified person check for the following on a periodic schedule determined by the user based upon the severity of the operating environment and the frequency of switch actuations:

- 1) Inspect the electrical wiring for continuity and damage.
- 2) Check to be certain that wiring conforms to the instructions given on pages 3 and 4 of this installation manual.

A designated person is identified in writing by the employer as being appropriately trained to perform a specified checkout procedure. A qualified person possesses a recognized degree or certificate or has extensive knowledge, training, and experience to be able to solve problems relating to the safety switch installation (ANSI B30.2).

Repairs

NOTE: Do not attempt any repairs to the switch. It contains no field-replaceable components. Return the switch to the factory for warranty repair or replacement.

If it ever becomes necessary to return a switch to the factory, please do the following:

- 1) Contact the Banner applications engineering department at the number or address listed on the front cover. They will attempt to troubleshoot the system from your description of the problem. If they conclude that a component is defective, they will issue an RMA (Return Merchandise Authorization) number for your paperwork, and give you the proper shipping address.
- 2) Pack the switch carefully. Damage which occurs in shipping is not covered by warranty.

Machine Safety Switches – Magnet Style

“Direction of Approach” options for sensor/magnet pairs

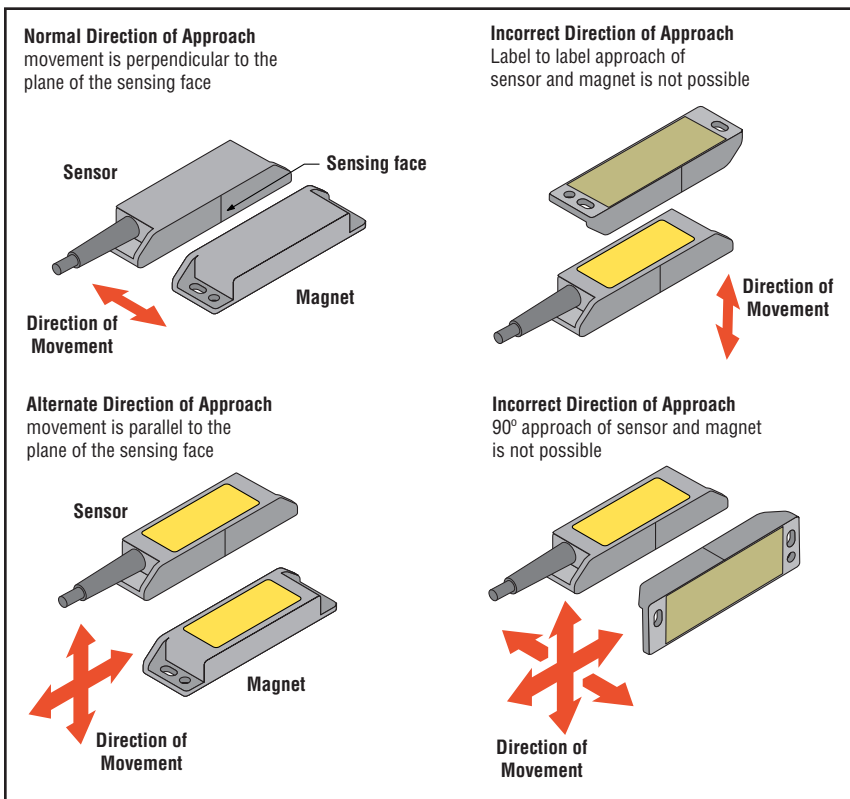

Figure 2a. Direction of Approach for SI-MAG1xx sensor/magnet pairs

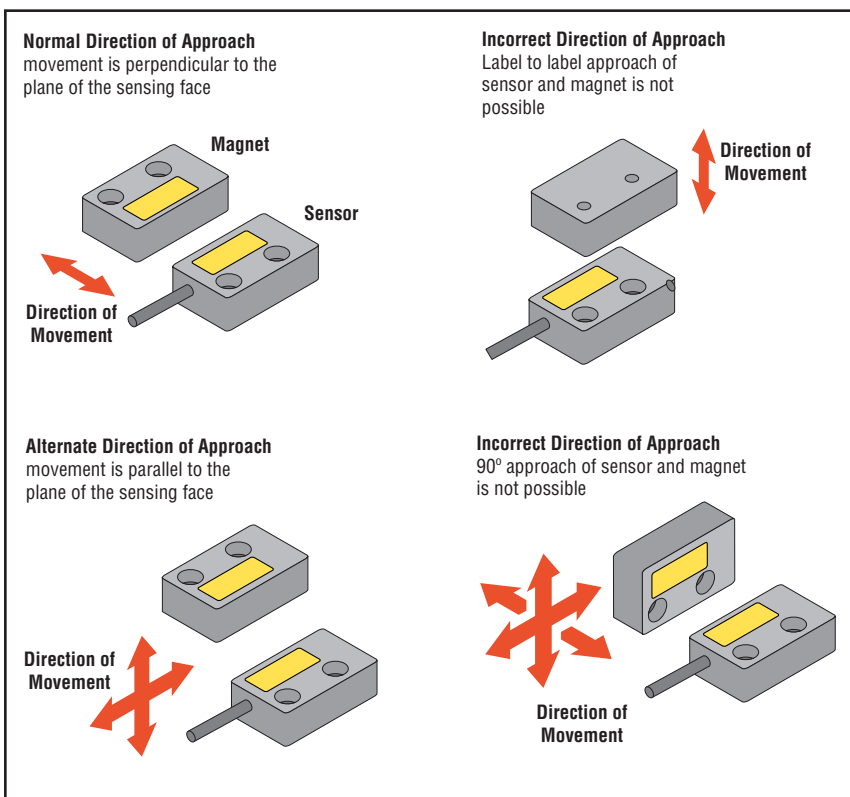

Figure 2b. Direction of Approach for SI-MAG2xx sensor/magnet pairs

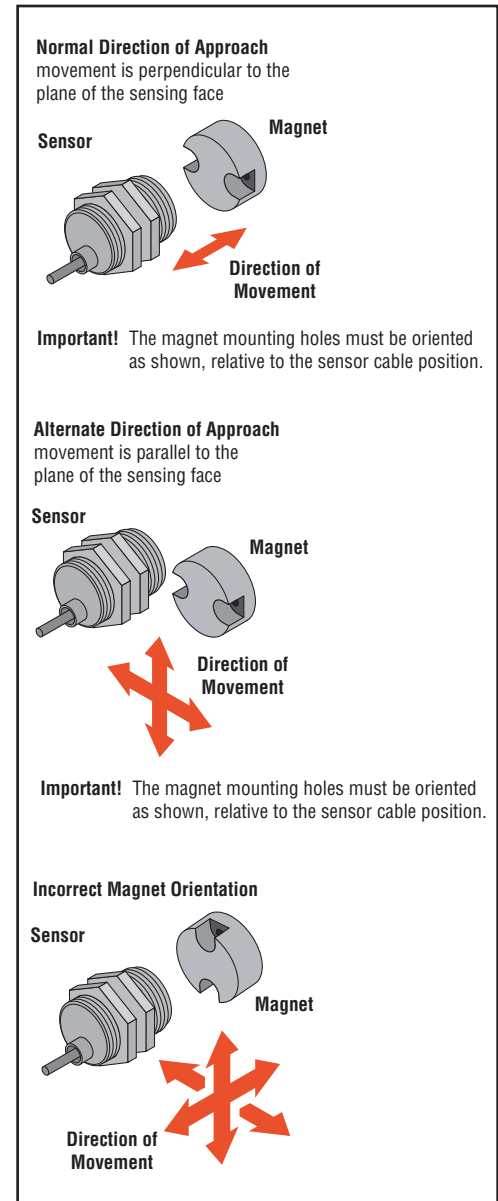

Figure 2c. Direction of Approach for SI-MAG3xx sensor/magnet pairs

NOTE: For all magnet style switches, approach speed must be greater than 0.2 m/s to allow for proper switching.

Machine Safety Switches – Magnet Style

Magnet Style Sensor Specifications

Switching Elements	Three pole-stable reed switches
Repeat Switching Accuracy	±0.1 mm (±0.004")
Construction	Epoxy-encapsulated circuit in polyamide housing
Environmental Rating	IEC IP67
Switching Capacity	30V dc max @0.25W
Operating Temperature	-5° to +70°C (+23° to +158°F)
Connections	Integral PVC-jacketed 3 m (10') 4-wire cable. Cable O.D. is 5 mm (0.2"). Wires are 24 AWG (0.25 mm ²).

Magnet Style Controller Specifications

Supply Voltage and Current	24V dc ±15% (15% maximum ripple) at less than 100mA
Sensor Compatibility	All magnet sensor models listed on page 1
Output Configuration	Two series-connected (redundant) normally-open safety relay contacts Contact Material: silver-nickel alloy Contact Ratings: Maximum Voltage: 250V ac Maximum Current: 8A ac Maximum Power: 1700VA Mechanical Life: 1,000,000 operations Electrical Life: 100,000 operations at full resistive load NOTE: Transient suppression is recommended when switching inductive loads. Install suppressors across load. Never install suppressors across output contacts
Auxiliary Non-safety Monitor Contact	Maximum Voltage: 120V ac, 24V dc Maximum Current: 0.25A (ac), 1.0 A (dc)
Simultaneity - Monitoring Period	The inputs from the sensor (terminals 1.1/1.2 and 1.3/1.4) must switch within 0.5 seconds of each other
Status Indicators	Green - Power ON Red - Sensor/Magnet out of position or open circuit in sensor wiring
Housing	Polycarbonate; Rated NEMA 1, IEC IP20
Mounting	Mounts to standard 35 mm DIN rail track. Must be installed inside an enclosure rated NEMA 3, IEC IP54 or better.
Wire Connections	Screw terminals with pressure plates accept wire size: 0.2 mm ² (26 AWG) min. to 2.5 mm ² (12 AWG) max.
Operating Temperature	0° to +55°C (+32° to +131°F)
Dimensions	See drawing on page 8.
Certifications	

Machine Safety Switches – Magnet Style

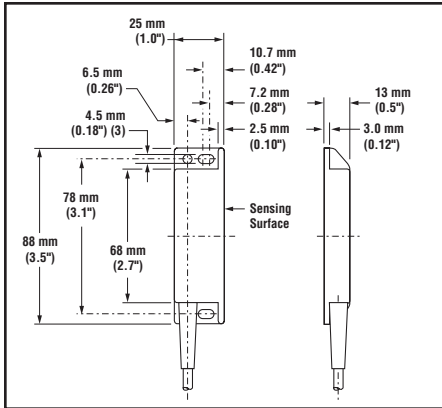

Figure 3a. SI-MAG1SM Sensor dimensions

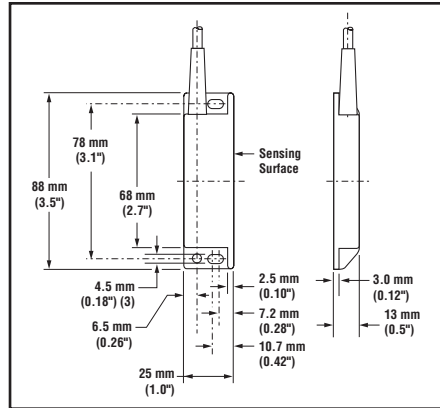

Figure 3b. SI-MAG1SMCO Sensor dimensions

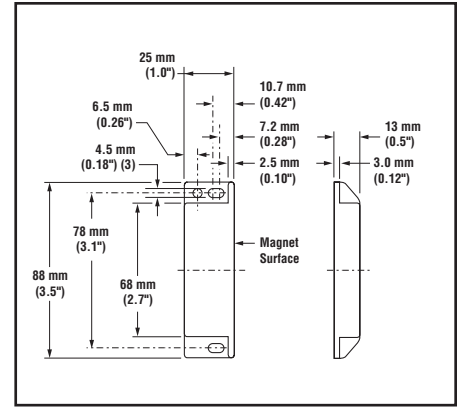

Figure 3c. SI-MAG1MM Magnet dimensions

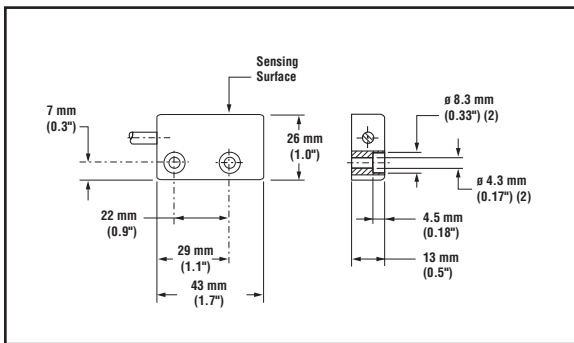

Figure 4a. SI-MAG2SM Sensor dimensions

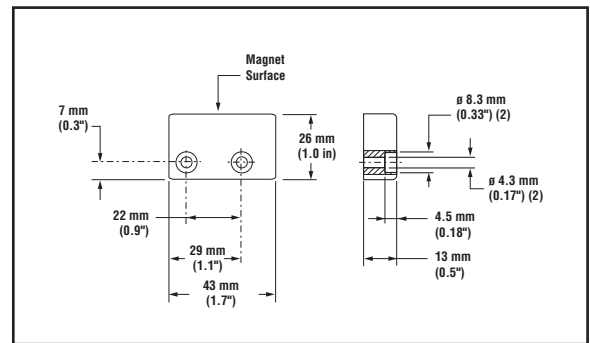

Figure 4b. SI-MAG2MM Magnet dimensions

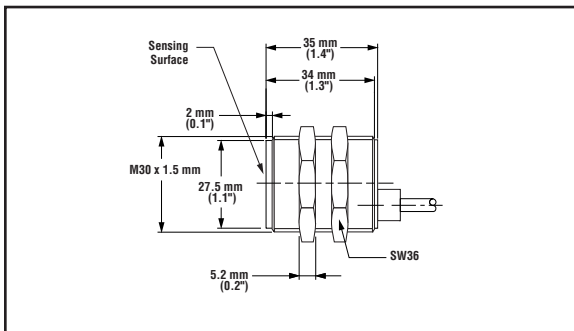

Figure 5a. SI-MAG3SM Sensor dimensions

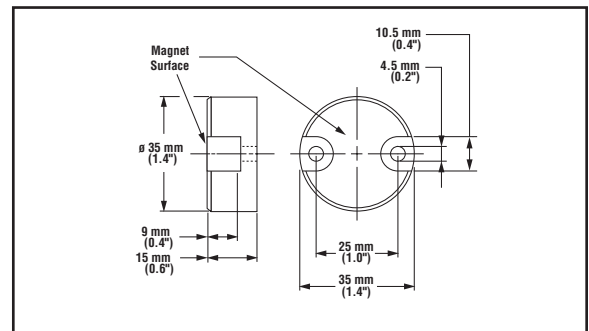

Figure 5b. SI-MAG3MM Magnet dimensions

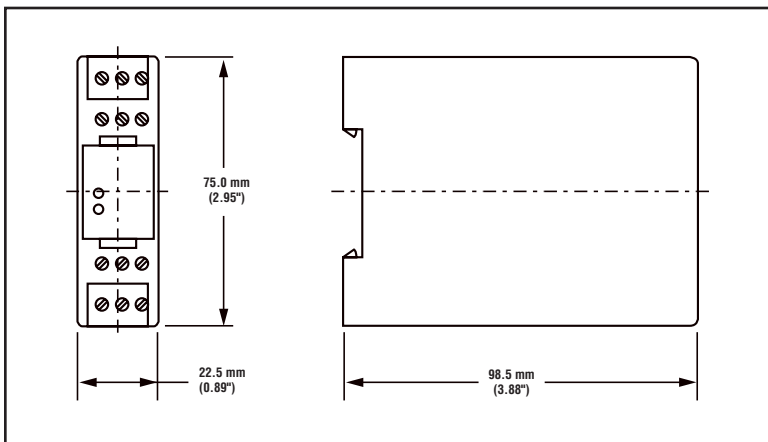

Figure 6. SI-MAG1C Controller dimensions



WARRANTY: Banner Engineering Corp. warrants its products to be free from defects for one year. Banner Engineering Corp. will repair or replace, free of charge, any product of its manufacture found to be defective at the time it is returned to the factory during the warranty period. This warranty does not cover damage or liability for the improper application of Banner products. This warranty is in lieu of any other warranty either expressed or implied.